

the **TIPPER**

Retort Basket Hydraulic Tip Machine

**RETORT ROOM MACHINERY FROM
THE RETORT PEOPLE**



RETORT ROOM EQUIPMENT

Allpax is a retort manufacturer that also builds a wide range of integrated robotics, automated material handling and auxiliary equipment for the retort room. The **TIPPER** is one of our designs that makes the retort room a safer place to work.

ELIMINATES EXCESS WATER

After the sterilization cycle, the retort water cooling cycle cools the product. But, the cooling cycle often creates a problem with excess water on the container lids and on the divider sheets. As the container cools with the water forming a pool on the lid, discoloration and rust spots can appear, giving you a problem that affects the throughput of your plant. Excess water on the divider sheets also introduces problems at the unloader, causing slippage with the automated pick & place operation. The Allpax **TIPPER** is a self-contained basket-tipping system, that is designed to lift and tip the retort baskets that have accumulated excess water from the cooling cycle of the retorting process.

45 DEGREE TIP / STAINLESS STEEL CONSTRUCTION

The **TIPPER** is manufactured and assembled using severe-duty components. The machine includes hydraulic packs that lift and tip fully loaded baskets of cans, jars, pouches and plastic containers. The basket tips to a 45 degree angle, allowing water to drain from the basket load and help to promote evaporation of the remaining moisture as the product continues to cool. The **TIPPER** is built with a heavy-duty welded 304-Stainless Steel frame. The frame is laser cut using computer control for exact precision and tolerances. The system is designed to support basket load weights in excess of 2500 pounds per basket.

CONTROLS

Each **TIPPER** comes with a 304 Stainless Steel Nema-4, free-standing operator / electrical panel. The controls are pushbutton and utilize sensors for lift position, along with a thru-beam safety sensor.

EQUIPMENT & SYSTEM FEATURES

- Single or Multi-Basket Models.
- Severe-Duty Design and Components.
- 304 Laser-Cut Stainless Frame Construction.
- 304 Stainless / NEMA-4 Operator / ElecPanel.
- Hydraulic Power Pack.
- Positive Basket Clamp-Down Arm for maintaining basket position during operation.
- Proximity Sensors and Thru-Beam Sensors that activate permissives for operator safety.
- Standard Components
- Push-Button Operator Interface
- Available for all dimensions of retort baskets.
- Easy Installation.

DIMENSIONS

See Reverse Side for General Equipment Layout. Contact Allpax with your specific basket size for exact dimensions.

The **Allpax** Line of Retort Room Equipment
RETORTS LOADERS AUTOMATION
HIGH TECHNOLOGY - LOW COST

ALLPAX

ALLPAX PRODUCTS, INC
13510 SEYMOUR MYERS BLVD., COVINGTON, LA 70433
985 . 893 . 9277 FAX 985 . 893 . 9477 www.allpax.com



the **TIPPER**

Retort Basket Hydraulic Tip Machine

DIMENSIONS

Dimensions shown are for one model only.
Call Allpax for the model and dimensional information for your retort.



The **TIPPER** with Self-Contained Controls

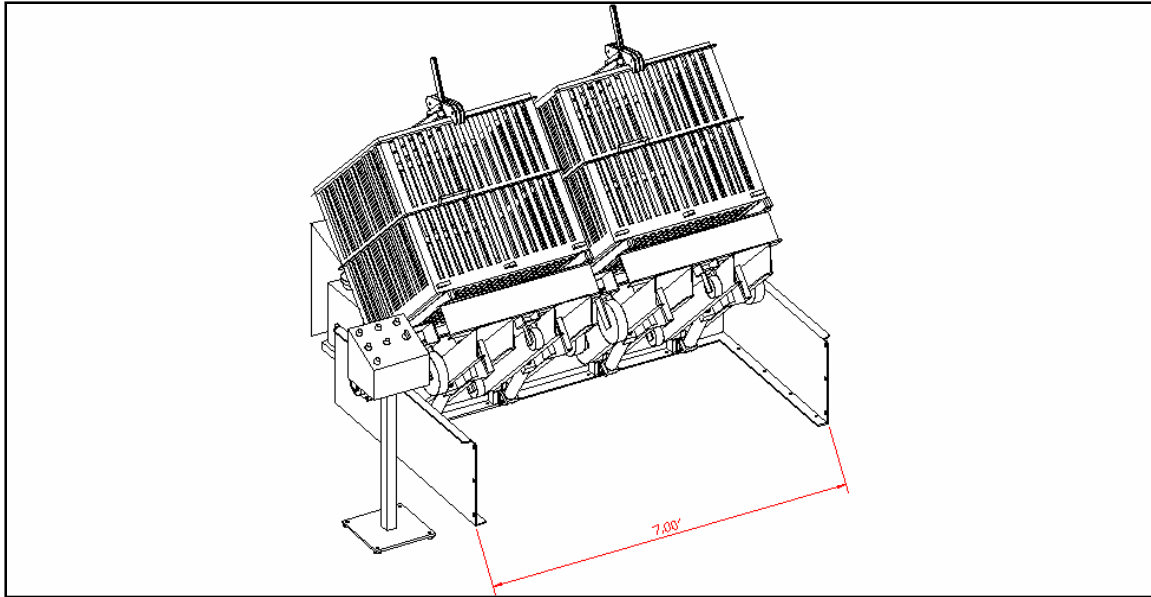

SIDE / ANGLE VIEW

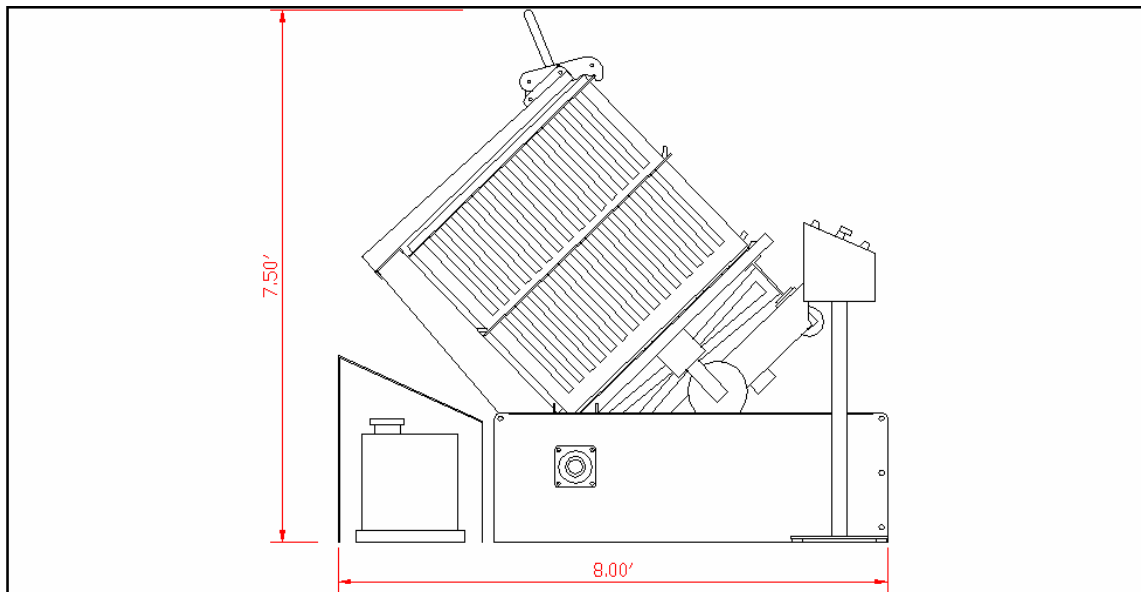

END VIEW

The **Allpax** Line of Retort Room Equipment
RETORTS LOADERS AUTOMATION
HIGH TECHNOLOGY - LOW COST

ALLPAX

ALLPAX PRODUCTS, INC
13510 SEYMOUR MYERS BLVD., COVINGTON, LA 70433
985 . 893 . 9277 FAX 985 . 893 . 9477 www.allpax.com